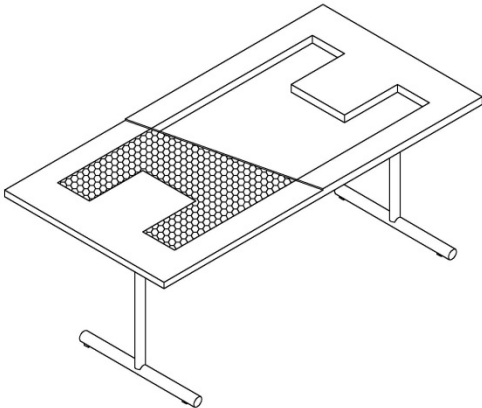

**Standard Construction Features:**

**Considerably lighter weight than standard table! (Averages 35% lighter).** Lightweight table tops have a 45lb. industrial particle board inner frame with a special honeycomb center core construction. High pressure decorative plastic laminate face with a HPL backing sheet on bottom are bonded together with a cross linking Poly Vinyl Acetate (PVA) adhesive under continuous pressure in a hydraulic press.

**Shapes and Sizes:**

*\*All top sizes listed are nominal size*

Shape	Sizes (W x L)
	18" x 60"
	18" x 72"
	18" x 84"
	24" x 60"
	24" x 72"
	24" x 84"
	30" x 60"
	30" x 72"
	30" x 84"
	36" x 60"
	36" x 72"
	36" x 84"

**Finishing Options:**

- Can be ordered with any choice of standard laminate offerings. See "Finishing Options" for more information.
- Can be made with available Shoto Corporation edge style offerings (**restrictions may apply**)

**Options & Accessories:**

- Custom power modules available (*See Shoto Corporation Accessories for more information*). If customer is supplying their own power module, Shoto can manufacture top with appropriate cutout. Proper cutout dimensions and applicable make, model, and part numbers must be provided by the customer.
- Contact factory for intermediate size options
- Can be paired Shoto Corporation Table Bases  
*See Shoto Corporation Table Bases and "Recommended Table Base Guide" for more information*